

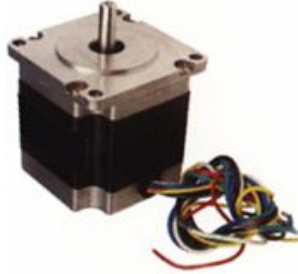

# 常州双杰电子有限公司

## SERIES HYBRID STEPPING MOTOR(混合式步进电机):

### 57BYGH(1.8°/0.9°) 2 相



### Wiring Diagram(接线图):

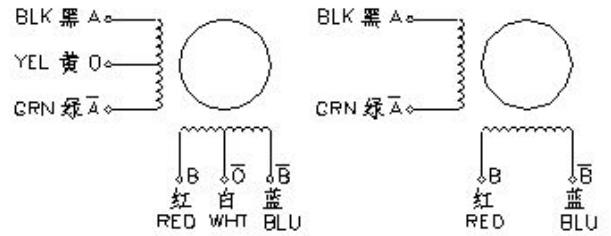

UNI-POLAR(6 LEADS)

BI-POLAR(4LEADS)

### Electrical Specifications(技术数据):

型号 Series Model	步距角 Step Angle (°)	机身長 Motor Length (mm)	电流 Rated Current (A)	电阻 Phase Resistance (Ω)	电感 Phase Inductance (mH)	静力矩 Holding Torque (Kg.cm)	定位力矩 Detent Torque (g.cm)	转动惯量 Rotor Inertia (g.cm <sup>2</sup> )	引线数 Lead Wire (NO.)	重量 Motor Weight (g)
57BYGH0601	1.8	41	1.0	5.2	5.5	4.0	250	150	6	470
57BYGH0408	1.8	41	2.0	0.8	1.5	4.8	250	150	4	470
57BYGH4412	1.8	45	0.6	12	28	7.6	280	190	4	520
57BYGH5602	1.8	51	0.8	6.3	8.0	7.0	300	230	6	590
57BYGH6602	1.8	56	1.5	3.2	5.4	9.0	350	280	6	590
57BYGH6403	1.8	56	2.5	1.1	3.6	10	350	280	4	680
57BYGH7401	1.8	64	1.0	7.0	22	14.5	500	380	4	850
57BYGH8603	1.8	76	1.5	4.2	9.2	15	600	440	6	1050
57BYGH8404	1.8	76	3.0	0.5	1.8	17	600	440	4	1050
57BYGH1810	1.8	100	3.0	1.4	2.5	20	1000	680	4	1250
57BYGH2810	1.8	112	3.0	1.6	3.5	25	1200	800	4	1400
57BYGH100D	1.8	100	3.5	1.8	3.7	2.8	1200	780	4	1250

\*以上仅为代表性产品,派生产品可根据客户要求制作!

### Dimensions(外形图): unit=mm

### Motor Length(机身说明):

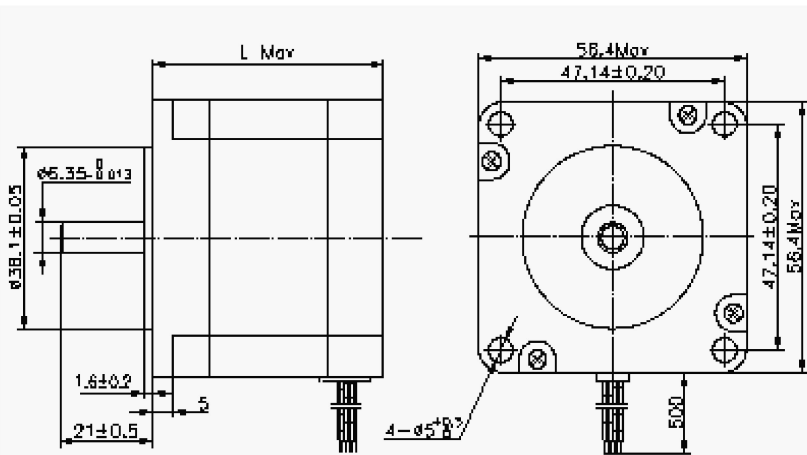

型号	机身長
57BYGH0XXX	41 mm
57BYGH4XXX	45 mm
57BYGH5XXX	51 mm
57BYGH6XXX	56 mm
57BYGH7XXX	64 mm
57BYGH8XXX	76 mm
57BYGH1XXX	100 mm
57BYGH2XXX	112 mm

常州双杰电子有限公司  
江苏省常州市戚墅堰芳渚村360号  
电话: 0519-88352577 88359735  
传真: 0519-88352858  
[www.czshuangjie.com](http://www.czshuangjie.com)

CHANGZHOU MOTORS AND ELECTRIC APPLIANCE CO.,LTD.  
Adrees:360 Fangzhu Qishuyan Changzhou China  
TEL: 086-519-88359735  
FAX: 086-519-88352858